

# Autolift System

**ADAPTER FOR DUCATO X250/290**  
**Art.465102**

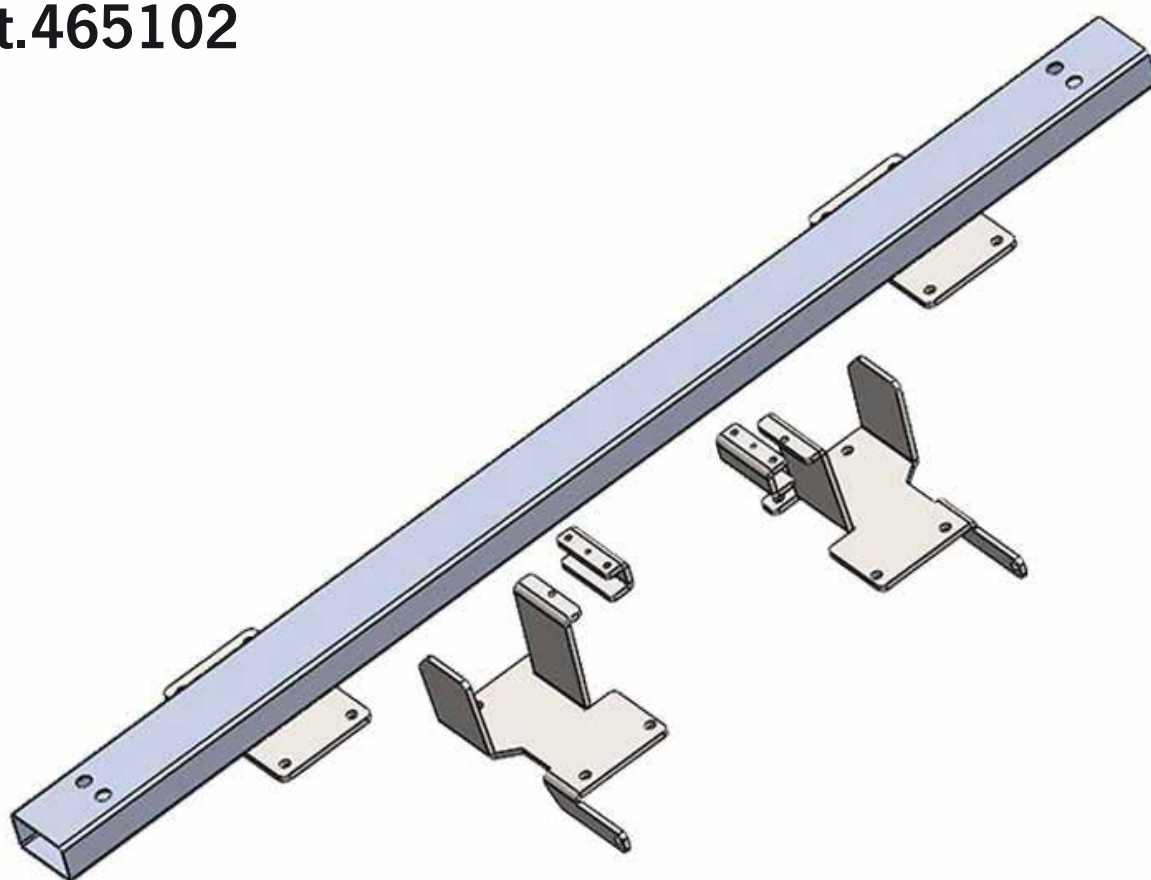

DE	-	BENUTZERHANDBUCH.....	2
EN	-	USER'S INSTRUCTION.....	9
IT	-	MANUALE D'ISTRUZIONI.....	17
ES	-	MANUAL DEL USUARIO.....	25
NL	-	INSTUCTIEHANDLEIDING.....	33
FR	-	MANUEL D'UTILISATION.....	41
FI	-	KÄYTTÖOHJE.....	49
DK	-	BRUGERHÅNDBOG.....	57
SE	-	ANVÄNDARMANUAL.....	65

## ADAPTER VORNE RECHTS DUCATO X250/290

### SCHRITT 1:



Bringen Sie den Adapter so weit wie möglich nach hinten. Entfernen Sie ggf. das Dichtungsmaterial, um eine bessere Haftung zu erreichen. Benutzen Sie einen Wagenheber, um die Halterung in der richtigen Position zu fixieren und bohren Sie ein seitliches Loch von 8 mm und befestigen Sie es dann mit einer Schraube.

### SCHRITT 2:



Bringen Sie die Klammer an.

Achtung! Der Wagenheber muss zur Außenseite des Fahrzeugs gerichtet sein, die Drehung muss nach vorne erfolgen

## ADAPTER VORNE LINKS DUCATO X250/290

### SCHRITT 1

Das gleiche Verfahren wie beim rechten Adapter anwenden

### SCHRITT 2



Die Schelle zwischen dem Tank und dem Chassis anbringen, dabei auf die Rohre achten. In einigen Fällen kann es notwendig sein, die Befestigungsschrauben des Tanks leicht zu lösen, um ihn 1-2 cm vom Chassis zu entfernen.

### SCHRITT 3:



In seltenen Fällen kann es notwendig sein, zu schleifen, damit sich der Wagenheber richtig dreht  
Achtung! Der Wagenheber muss zur Außenseite des Fahrzeugs gerichtet sein, die Drehung muss nach vorne erfolgen.

(HINWEIS)  
ES IST MÖGLICH, DEN HINTEREN ADAPTER VOR ODER HINTER DER HINTERACHSE ZU BEFESTIGEN

### HECKADAPTER DUCATO X250 (VOR DER HINTERACHSE)

#### SCHRITT 1:

Der hintere Adapter muss hinter der Hinterachse angebracht werden, wie auf dem Foto gezeigt:

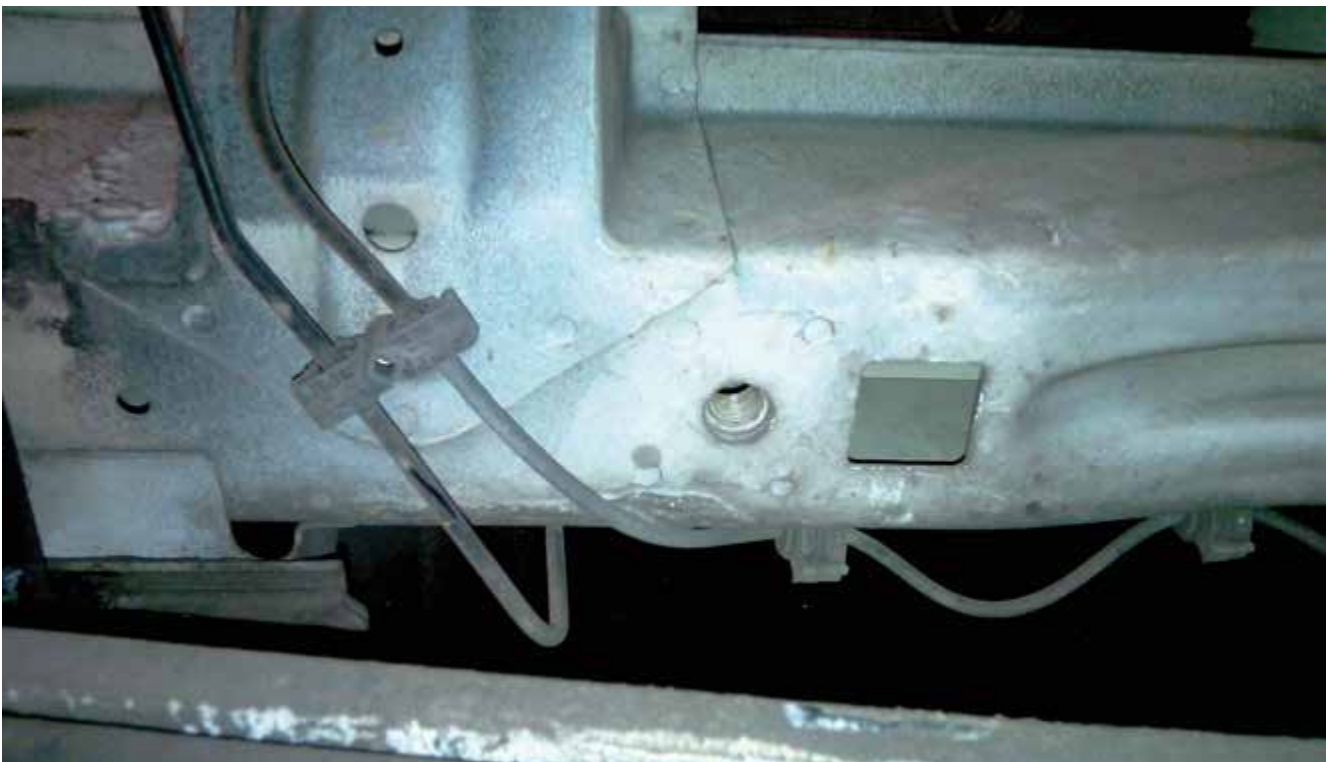

## HECKADAPTER DUCATO X250 (VOR DER HINTERACHSE)

### SCHRITT 2:



Positionieren Sie die Dichtungsplatte (Platte mit einem Loch) und setzen Sie sie ein, dann befestigen Sie sie mit den Schrauben (10 mm x 70 mm und 14 mm x 70 mm)

Achtung! Beide hinteren Wagenheber mit Motor zur Fahrzeugmitte, Drehung nach vorne.

## HECKADAPTER DUCATO X250 (HINTER DER HINTERACHSE)

### SCHRITT 1:





(elektrische Verkabelung verschieben, Adapter darüber einsetzen)



**SCHRITT 2:**

Den Adapter mit den Schrauben (4 Stück - 10 mm x 70 mm) befestigen, dann die Wagenheber anbringen.



Achtung: Die beiden hinteren Wagenheber müssen so platziert werden, dass der Motor zur Mitte des Fahrzeugs zeigt und sich nach vorne oder nach hinten drehen kann.



# Autolift System

---

**ADAPTER FOR DUCATO X250/290**  
**Art.465102**

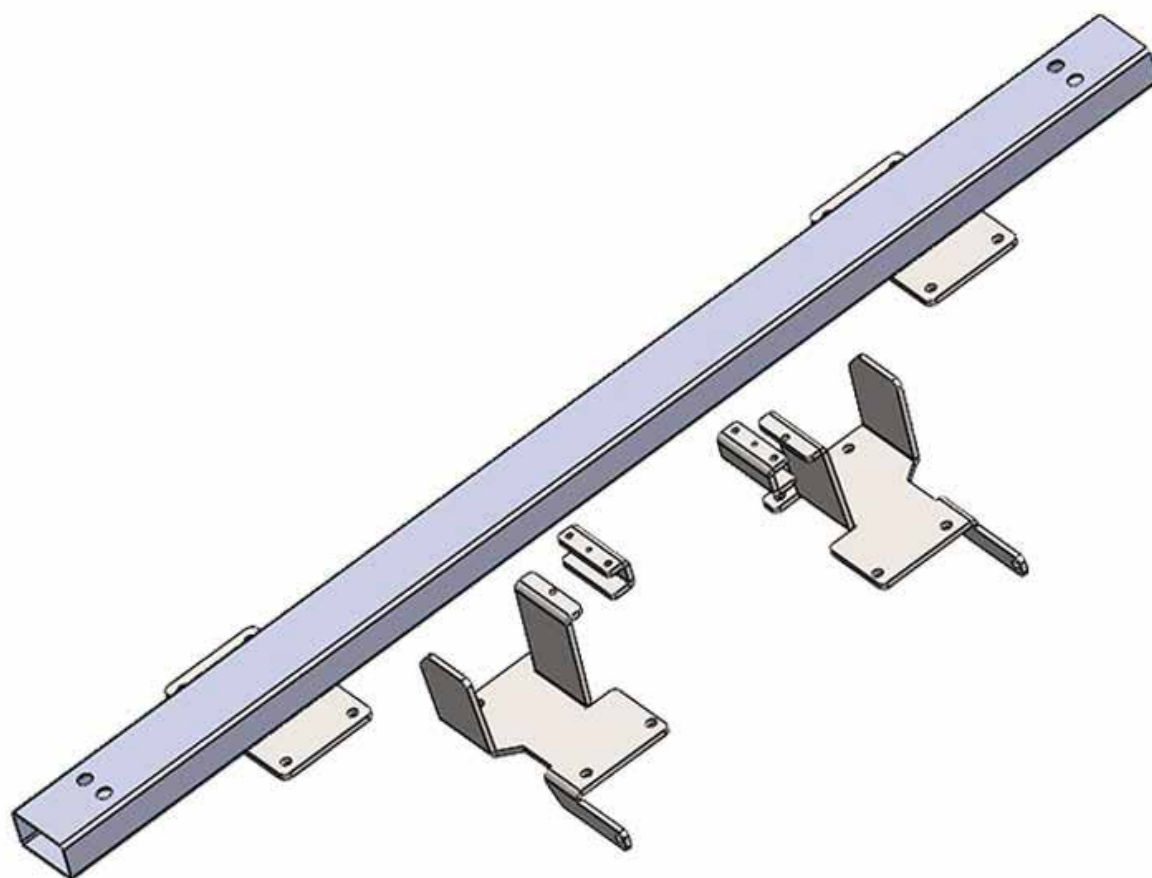

## FRONT RIGHT ADAPTER DUCATO X250/290

### STEP 1:



Put the adapter as far back as possible. If necessary remove any sealing material for greater adherence. Use a bottle jack to fix the bracket in the correct position and make an 8 mm side hole, then fix it with a bolt.

### STEP 2:



Apply the clamp.

Attention: Motor jack positioned facing towards the outside of the vehicle, rotation towards the front.

## FRONT LEFT ADAPTER DUCATO X250/290

### STEP 1:

Use the same procedure of the right adapter

### STEP 2:



Place the clamp between the tank and the chassis, pay attention to the pipes. In some cases it may be necessary to slightly loosen the screws fixing the tank, to move it away from the chassis 1-2 cm.

### STEP 3:



In rare cases it may be necessary to sand, in pursuance of the correct rotation of the jack.  
Attention: Motor jack placed facing toward the outside of the vehicle, rotation towards the front.

(NOTICE) IT IS POSSIBLE TO FIX THE REAR ADAPTER AHEAD OR BEHIND THE REAR AXLE

REAR ADAPTER DUCATO X250 (AHEAD OF THE REAR AXLE)

STEP 1:

The rear adapter must be placed behind the rear axle, as shown in the photo:

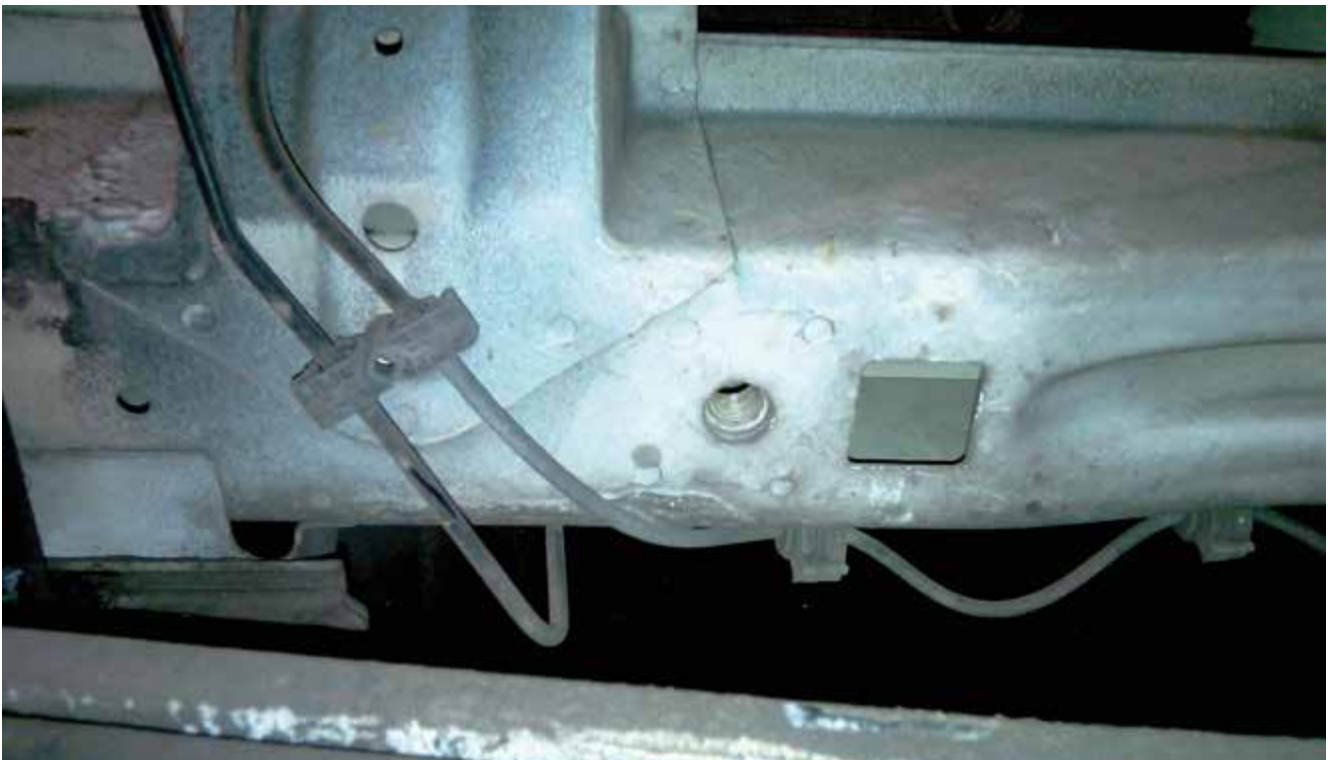

## REAR ADAPTER DUCATO X250 (AHEAD OF THE REAR AXLE)

### STEP 2:



Position and insert the sealing plate (plate with one hole), then fix with the bolts (10 mm x 70 mm and 14 mm x 70 mm).

Attention: Both rear jacks with engine toward the center of the vehicle, rotation towards the front.

## REAR ADAPTER DUCATO X250 (BEHIND THE REAR AXLE)

### STEP 1:





(move the electrical wiring, insert the adapter above it)



**STEP 2:**

Fix the adapter using the bolts (4 pieces – 10 mm x 70 mm), then fix the jacks.



Beware: Both rear jacks should be placed with the engine towards the center of the vehicle, being able to rotate towards the front or towards the rear.



# Autolift System

---

**ADATTATORE PER DUCATO X250/290**  
**Art.465102**

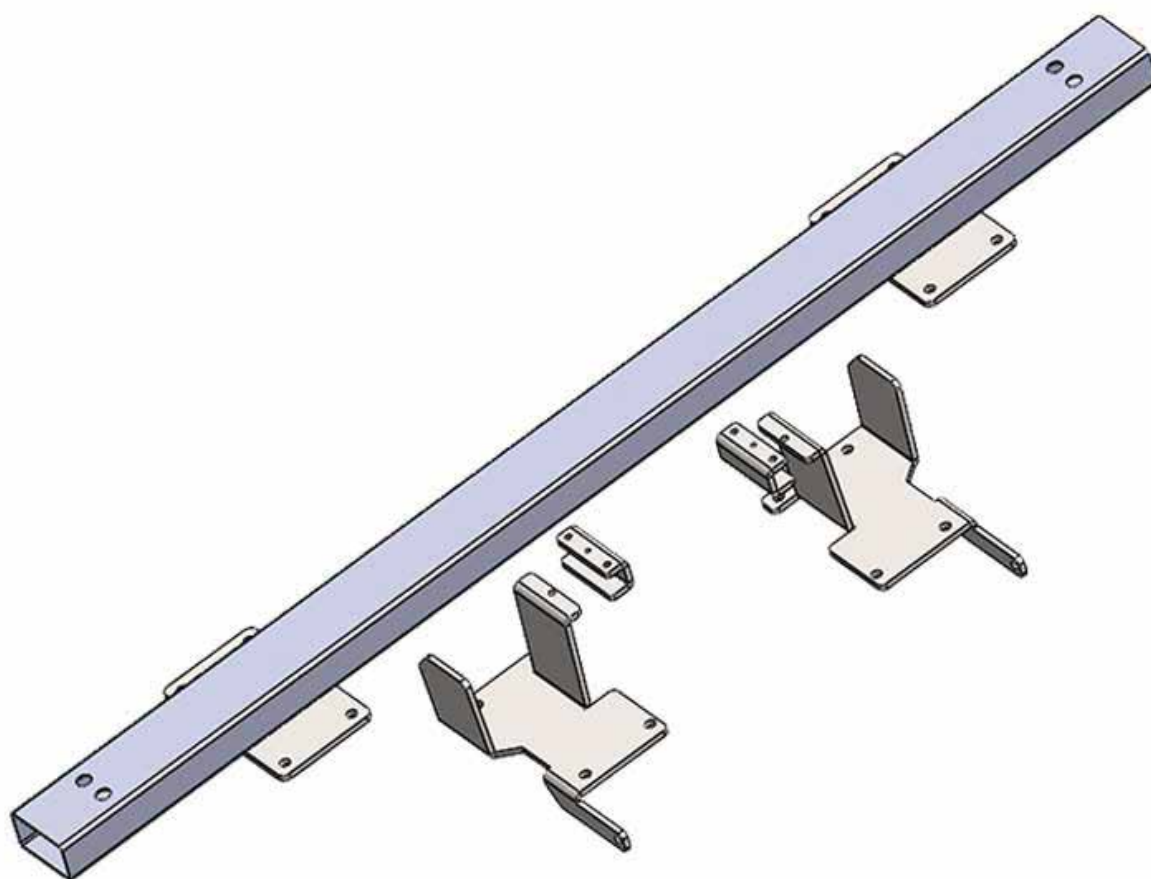

## ADATTATORE ANTERIORE DESTRO DUCATO X250/290

### PASSO 1:



Arretrare il più possibile l'adattatore. Se necessario, rimuovere il materiale sigillante per una maggiore aderenza. Utilizzare un martinetto per fissare la staffa nella posizione corretta e praticare un foro laterale di 8 mm, quindi fissarlo con un bullone.

### PASSO 2:



Applicare il morsetto

Attenzione: Martinetto motore rivolto verso l'esterno del veicolo, rotazione verso la parte anteriore

## ADATTATORE ANTERIORE SINISTRO DUCATO X250/290

### PASSO 1

Utilizzare la stessa procedura dell'adattatore destro

### PASSO 2



Posizionare il morsetto tra il serbatoio e il telaio, facendo attenzione ai tubi. In alcuni casi potrebbe essere necessario allentare leggermente le viti di fissaggio del serbatoio, per allontanarlo dal telaio di 1-2 cm.

### PASSO 3:



In rari casi può essere necessario carteggiare, per ottenere la corretta rotazione del martinetto  
Attenzione: Martinetto motore rivolto verso l'esterno del veicolo, rotazione verso la parte anteriore.

(AVVISO) È POSSIBILE FISSARE L'ADATTATORE POSTERIORE DAVANTI O DIETRO L'ASSE POSTERIORE

ADATTATORE POSTERIORE DUCATO X250 (DAVANTI ALL'ASSE POSTERIORE)

PASSO 1:

L'adattatore posteriore deve essere posizionato dietro l'asse posteriore, come mostrato nella foto:

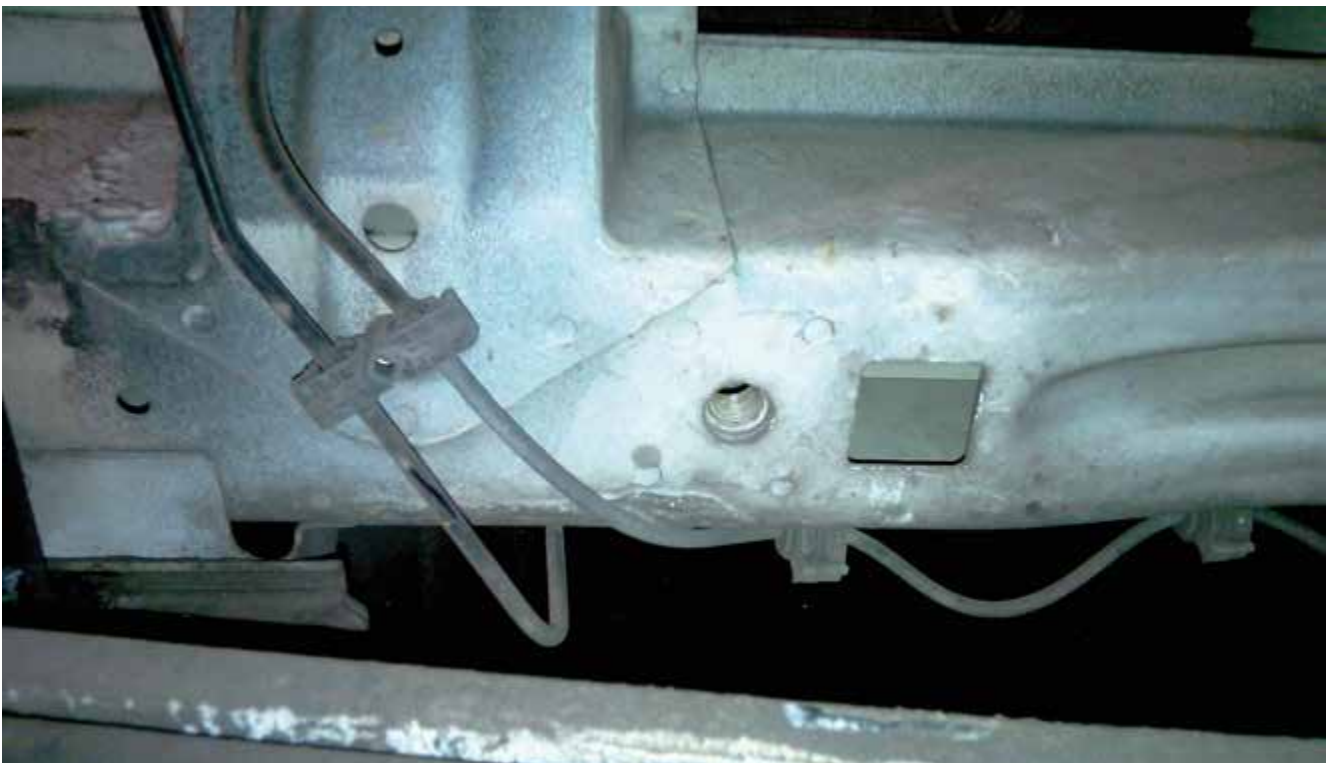

## ADATTATORE POSTERIORE DUCATO X250 (DAVANTI ALL'ASSE POSTERIORE)

### PASSO 2:



Posizionare e inserire la piastra di tenuta (piastra con un foro), quindi fissarla con i bulloni (10 mm x 70 mm e 14 mm x 70 mm)

Attenzione: Entrambi i martinetti posteriori con il motore verso il centro del veicolo, rotazione verso la parte anteriore.

## ADATTATORE POSTERIORE DUCATO X250 (DIETRO L'ASSE POSTERIORE)

### PASSO 1:





(spostare il cablaggio elettrico, inserire l'adattatore sopra di esso)



**PASSO 2:**

Fissare l'adattatore con i bulloni (4 pezzi - 10 mm x 70 mm), quindi fissare i martinetti.



Attenzione: entrambi i martinetti posteriori devono essere posizionati con il motore verso il centro del veicolo, potendo ruotare verso la parte anteriore o posteriore.



# Autolift System

---

**ADAPTADOR PARA DUCATO X250/290**  
**Art.465102**

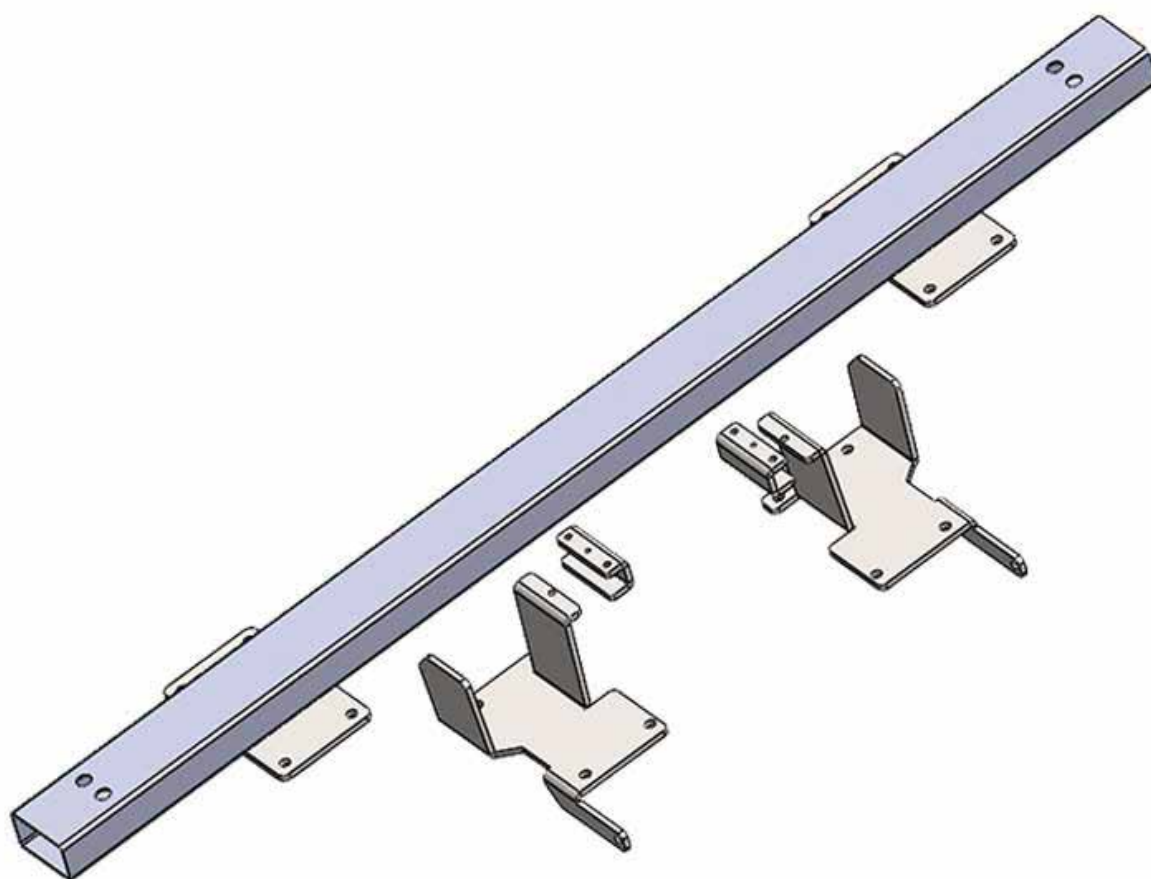

## ADAPTADOR DELANTERO DERECHO DUCATO X250/290

### PASO 1:



Coloque el adaptador lo más atrás posible. Si es necesario, retire el material de sellado para una mayor adherencia. Utilice un gato de botella para fijar el adaptador en la posición correcta y haga un agujero lateral de 8 mm, luego fíjelo con un tornillo.

### PASO 2:



Aplice la abrazadera

Atención: Colocar el gato de motor hacia el exterior del vehículo, la rotación hacia la parte delantera

## ADAPTADOR DELANTERO IZQUIERDO DUCATO X250/290

### PASO 1

Utilice el mismo procedimiento del adaptador derecho

### PASO 2



Colocar la abrazadera entre el depósito y el chasis, prestando atención a los tubos. En algunos casos puede ser necesario aflojar ligeramente los tornillos que fijan el depósito, para alejarlo del chasis 1-2 cm.

### PASO 3:



En raros casos puede ser necesario lijar, en pos de la correcta rotación del gato  
Atención: Gato motor colocado hacia el exterior del vehículo, rotación hacia la parte delantera.

(AVISO) ES POSIBLE FIJAR EL ADAPTADOR TRASERO POR DELANTE O POR DETRÁS DEL EJE TRASERO

### ADAPTADOR TRASERO DUCATO X250 (POR DELANTE DEL EJE TRASERO)

#### PASO 1:

El adaptador trasero debe colocarse detrás del eje trasero, como se muestra en la foto:

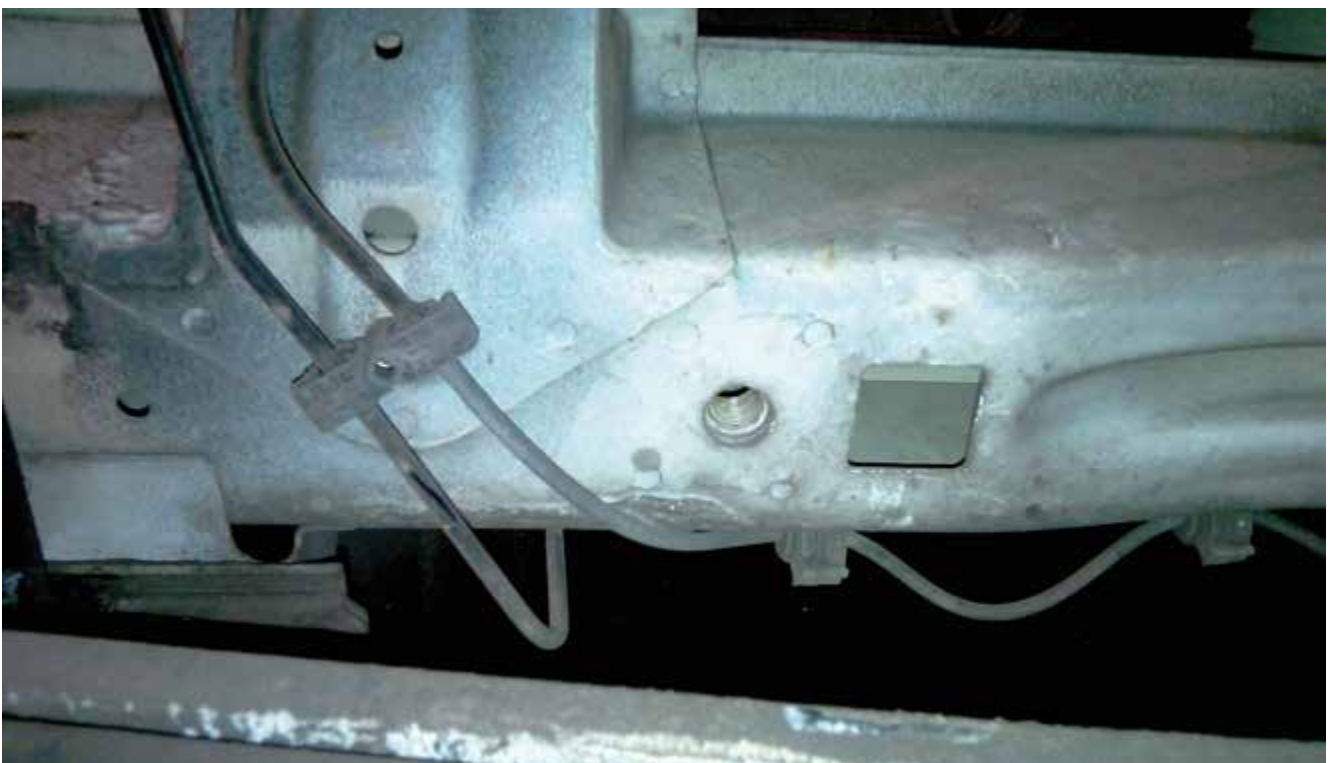

## ADAPTADOR TRASERO DUCATO X250 (POR DELANTE DEL EJE TRASERO)

### PASO 2:



Coloque e inserte la placa de sellado (placa con un orificio), luego fijela con los tornillos (10 mm x 70 mm y 14 mm x 70 mm)

Atención: Los dos gatos traseros con el motor hacia el centro del vehículo, la rotación hacia la parte delantera.

## ADAPTADOR TRASERO DUCATO X250 (DETRÁS DEL EJE TRASERO)

### PASO 1:





(mover el cableado eléctrico, insertar el adaptador por encima)



**PASO 2:**

Fijar el adaptador con los tornillos (4 piezas - 10 mm x 70 mm), luego fijar los gatos.



Atención: Los dos gatos traseros deben colocarse con el motor hacia el centro del vehículo, pudiendo girar hacia delante o hacia atrás.



# Autolift System

---

**ADAPTER VOOR DUCATO X250/290**  
**Art.465102**

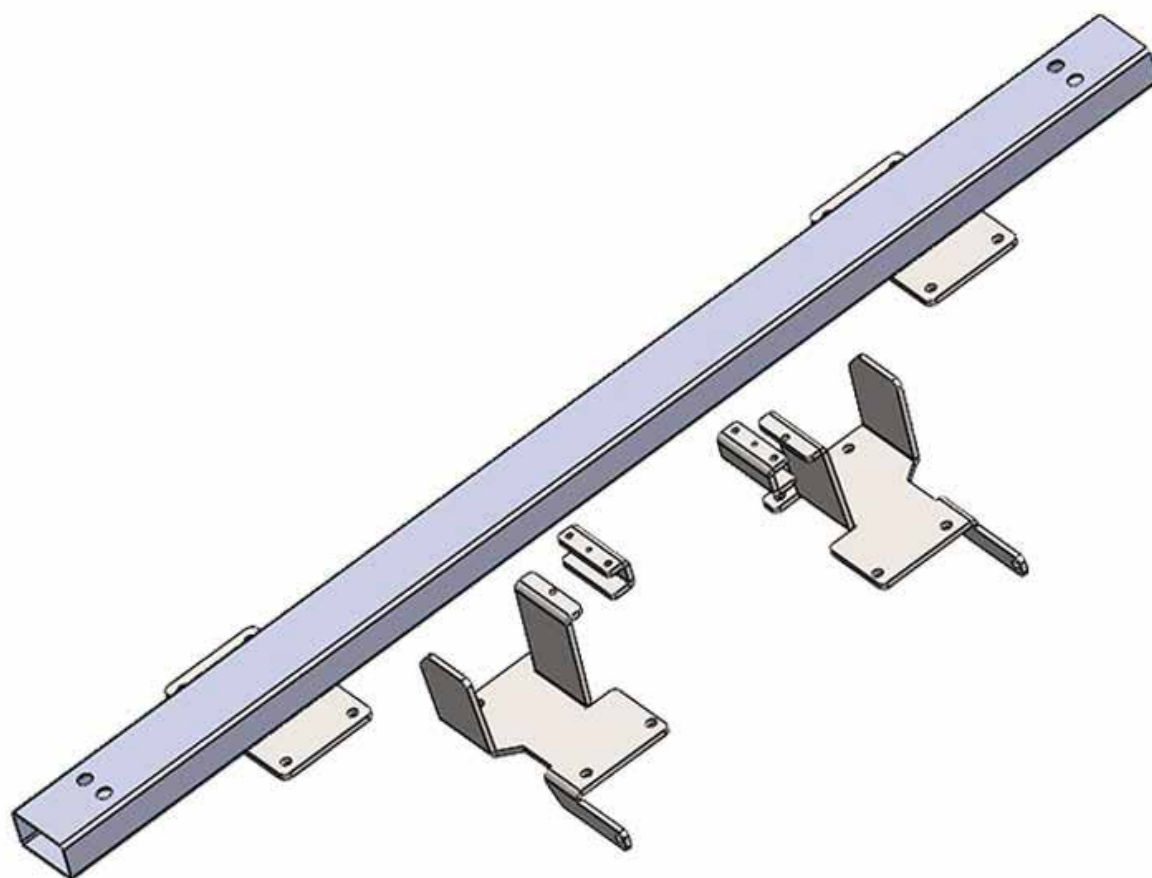

## ADAPTER RECHTSVOOR DUCATO X250/290

### STAP 1:



Plaats de adapter zo ver mogelijk naar achteren. Verwijder eventueel afdichtingsmateriaal voor een betere hechting. Gebruik een flessenkrik om de beugel in de juiste positie vast te zetten en maak een gat van 8 mm aan de zijkant, zet het vervolgens vast met een bout.

### STAP 2:



Breng de klem aan

Let op: Motorkrik naar de buitenkant van het voertuig gericht, draaiing naar voren

## ADAPTER LINKSVOOR DUCATO X250/290

### STAP 1

Gebruik dezelfde procedure als bij de rechter adapter

### STAP 2



Plaats de klem tussen de tank en het chassis, let hierbij op de leidingen. In sommige gevallen kan het nodig zijn de schroeven waarmee de tank is bevestigd, iets los te draaien om de tank 1-2 cm van het chassis te verplaatsen.

### STAP 3:



In zeldzame gevallen kan het nodig zijn om te schuren, met het oog op de juiste rotatie van de krik  
Opgelet: Motorkrik naar de buitenkant van het voertuig gericht, draaiing naar voren.

(OPGELET) HET IS MOGELIJK OM DE ACHTERADAPTER VOOR OF ACHTER DE ACHTERAS TE BEVESTIGEN

### ACHTERADAPTER DUCATO X250 (VÓÓR DE ACHTERAS)

#### STAP 1:

De achteradapter moet achter de achteras worden geplaatst, zoals op de foto te zien is:

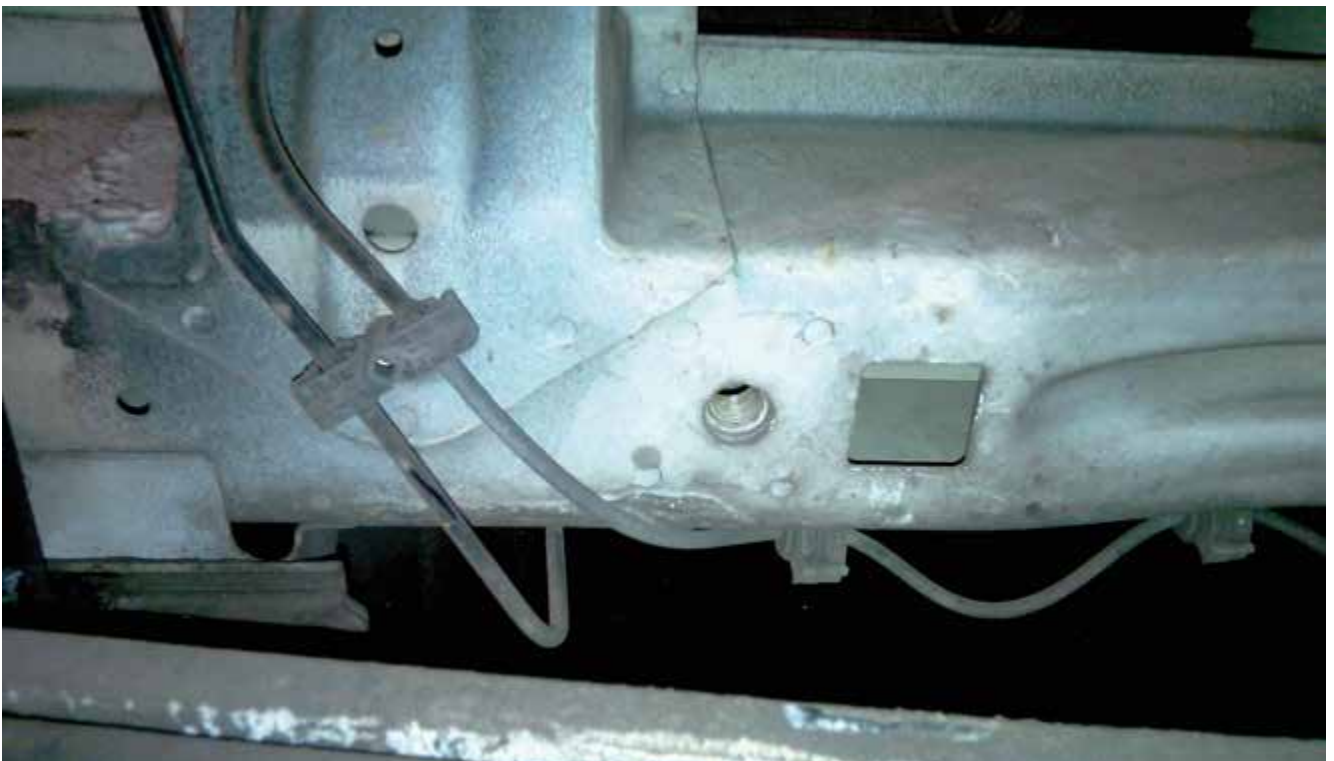

## ACHTERADAPTER DUCATO X250 (VÓÓR DE ACHTERAS)

### STAP 2:



Plaats en plaats de afdichtplaat (plaat met één gat), zet vervolgens vast met de bouten (10 mm x 70 mm en 14 mm x 70 mm)

Let op: Beide achterpoten met de motor naar het midden van het voertuig, draaiing naar voren.

## ACHTERADAPTER DUCATO X250 (ACHTER DE ACHTERAS)

### STAP 1:





(verplaats de elektrische bedrading, plaats de adapter erboven)



**STAP 2:**

Zet de adapter vast met de bouten (4 stuks - 10 mm x 70 mm), zet daarna de steunen vast.



Opgelet: Beide achterpoten moeten met de motor naar het midden van het voertuig worden geplaatst, zodat ze naar voren of naar achteren kunnen draaien.



# Autolift System

---

**ADAPTATEUR POUR DUCATO X250/290**  
**Art.465102**

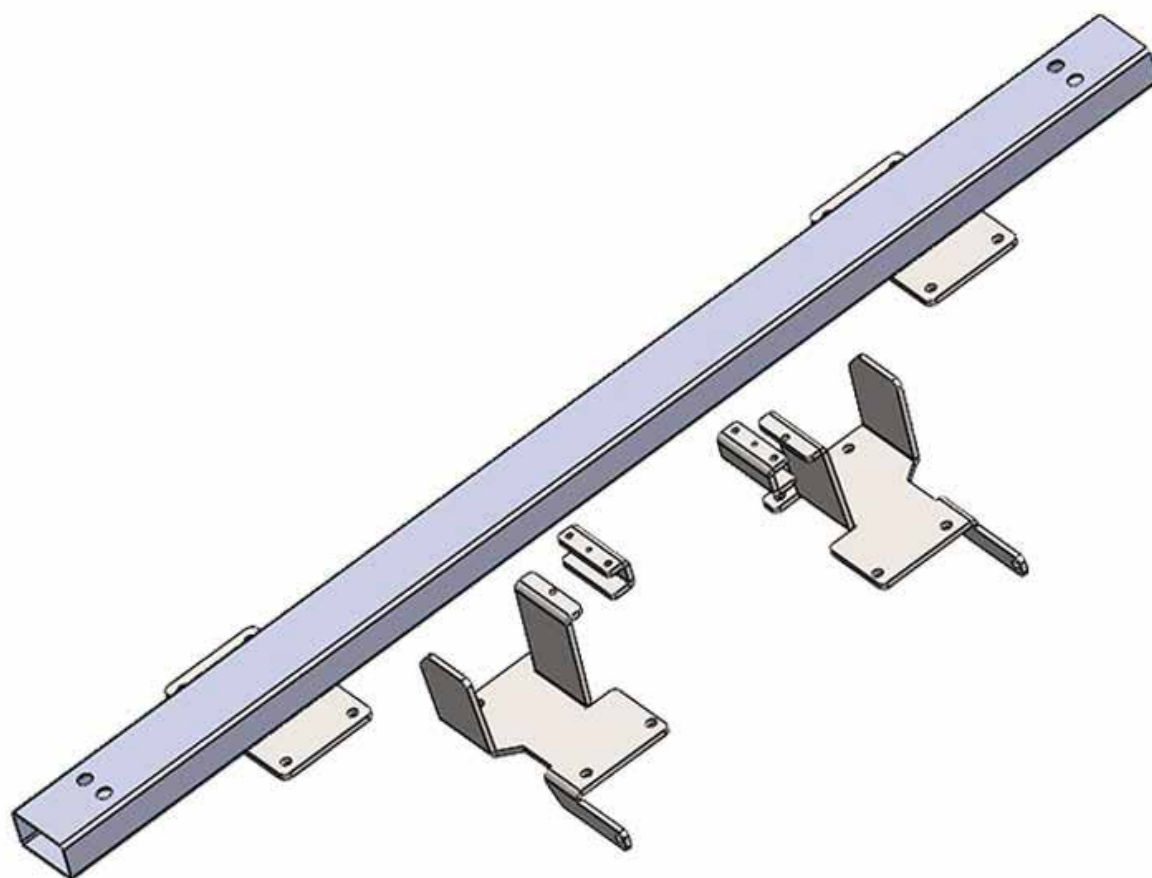

## ADAPTATEUR AVANT DROIT DUCATO X250/290

### ÉTAPE 1 :



Mettre l'adaptateur aussi loin en arrière que possible. Si nécessaire, enlever tout matériau d'étanchéité pour une meilleure adhérence. Utiliser un porte-bouteille pour fixer le support dans la bonne position et faire un trou de 8 mm sur le côté, puis le fixer avec une vis.

### ÉTAPE 2 :



Appliquer la pince

Attention : la prise moteur doit être positionnée face à l'extérieur du véhicule, la rotation face à l'avant

## ADAPTATEUR AVANT GAUCHE DUCATO X250/290

### ÉTAPE 1

Utiliser la même procédure que pour l'adaptateur droit

### ÉTAPE 2



Placez la pince entre le réservoir et le châssis, faites attention aux tuyaux. Dans certains cas, il peut être nécessaire de desserrer légèrement les vis de fixation du réservoir pour l'éloigner de 1 à 2 cm du châssis.

### ÉTAPE 3 :



Dans de rares cas, il peut être nécessaire de sabler, dans le but d'obtenir une rotation correcte de la manille  
Attention : la manette du moteur est placée face à l'extérieur du véhicule, la rotation vers l'avant.

(REMARQUE) IL EST POSSIBLE DE FIXER L'ADAPTATEUR ARRIÈRE À L'AVANT OU À L'ARRIÈRE DE L'ESSIEU ARRIÈRE

### ADAPTATEUR ARRIÈRE DUCATO X250 (À L'AVANT DE L'ESSIEU ARRIÈRE)

#### ÉTAPE 1 :

L'adaptateur arrière doit être placé derrière l'essieu arrière, comme indiqué sur la photo :

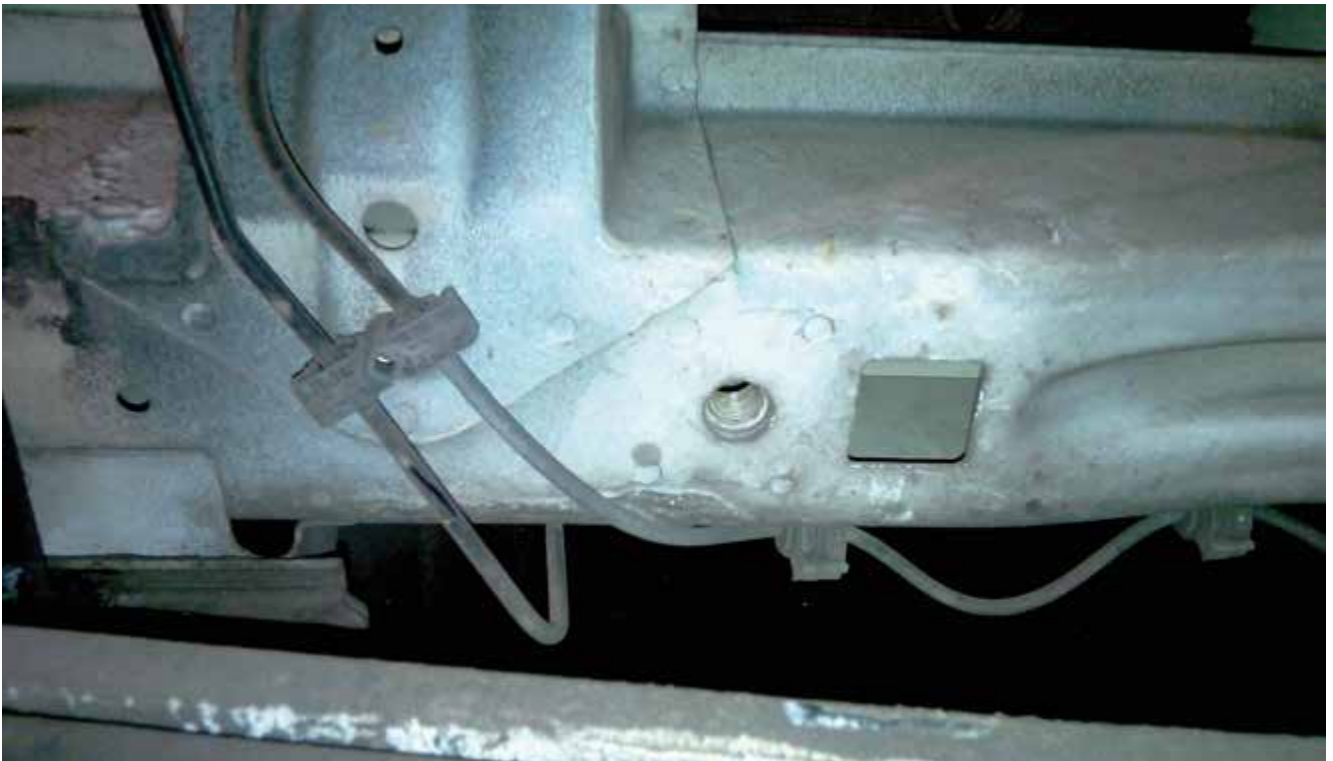

## ADAPTATEUR ARRIÈRE DUCATO X250 (À L'AVANT DE L'ESSIEU ARRIÈRE)

### ÉTAPE 2 :



Positionner et insérer la plaque d'étanchéité (plaque avec un trou), puis la fixer avec les vis (10 mm x 70 mm et 14 mm x 70 mm)

Attention : les deux jacks arrière avec le moteur vers le centre du véhicule, rotation vers l'avant.

## ADAPTATEUR ARRIÈRE DUCATO X250 (DERRIÈRE L'ESSIEU ARRIÈRE)

ÉTAPE 1 :





(déplacer le câblage électrique, insérer l'adaptateur au-dessus de lui)



**ÉTAPE 2 :**

Fixer l'adaptateur à l'aide des boulons (4 pièces - 10 mm x 70 mm), puis fixer les jacks.



Attention : les deux jacks arrière doivent être placés avec le moteur vers le centre du véhicule, en pouvant être tournés vers l'avant ou vers l'arrière.



# Autolift System

---

**ADAPTERI DUCATO X250/290**  
**Art.465102**

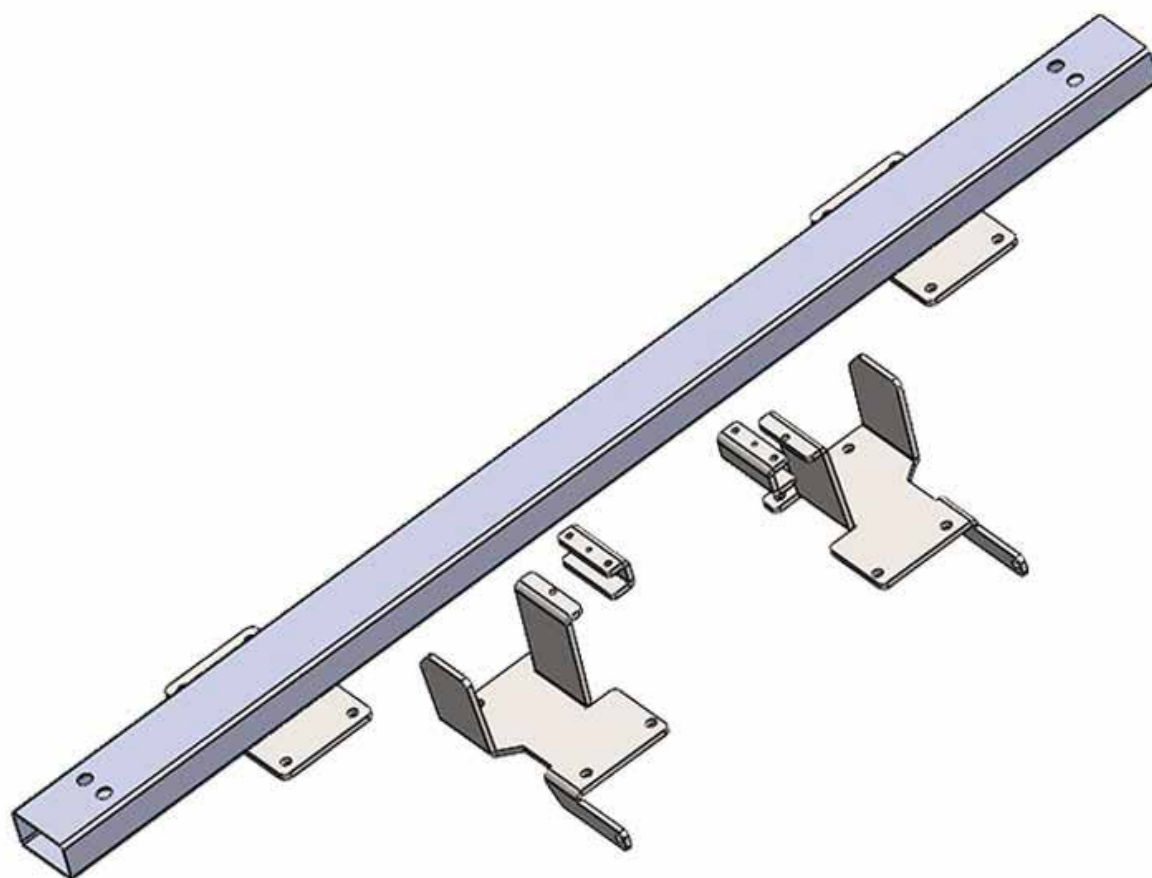

## OIKEA ETUSOVITIN DUCATO X250/290

### VAIHE 1:



Aseta sovitin mahdollisimman kauas taakse. Tarvittaessa poista mahdollinen tiivistysmateriaali, jotta kiinnittyminen paranee. Kiinnitä kiinnike oikeaan asentoon pullotunkilla ja tee 8 mm:n sivureikä ja kiinnitä se sitten pultilla.

### VAIHE 2:



Kiinnitä kiinnitin

Huomio! Moottoritunkki asennetaan ajoneuvon ulkopuolelle päin, kierto eteen päin

## VASEMMANPUOLEINEN ETUSOVITIN DUCATO X250/290

### VAIHE 1

Noudata samaa menettelyä kuin oikean sovittimen kohdalla

### VAIHE 2



Aseta kiinnitin säiliön ja alustan väliin, kiinnitä huomiota putkiin. Joissakin tapauksissa voi olla tarpeen löysätä hieman säiliön kiinnitysruuveja, jotta säiliötä voidaan siirtää 1-2 cm pois päin alustasta.

### VAIHE 3:



Harvoissa tapauksissa voi olla tarpeen hioa, jotta tunkki kääntyy oikein  
Huomio! Moottoritunkki asetetaan ajoneuvon ulkopuolelle päin, kierto eteen päin.

(HUOM.) TAKASOVITIN ON MAHDOLLISTA KIINNITTÄÄ TAKA-AKSELIN ETEEN TAI TAAKSE

TAKA-ADAPTERI DUCATO X250 (TAKA-AKSELIN ETEEN)

VAIHE 1:

Taka-adapteri on sijoitettava taka-akselin taakse, kuten kuvassa näkyy:

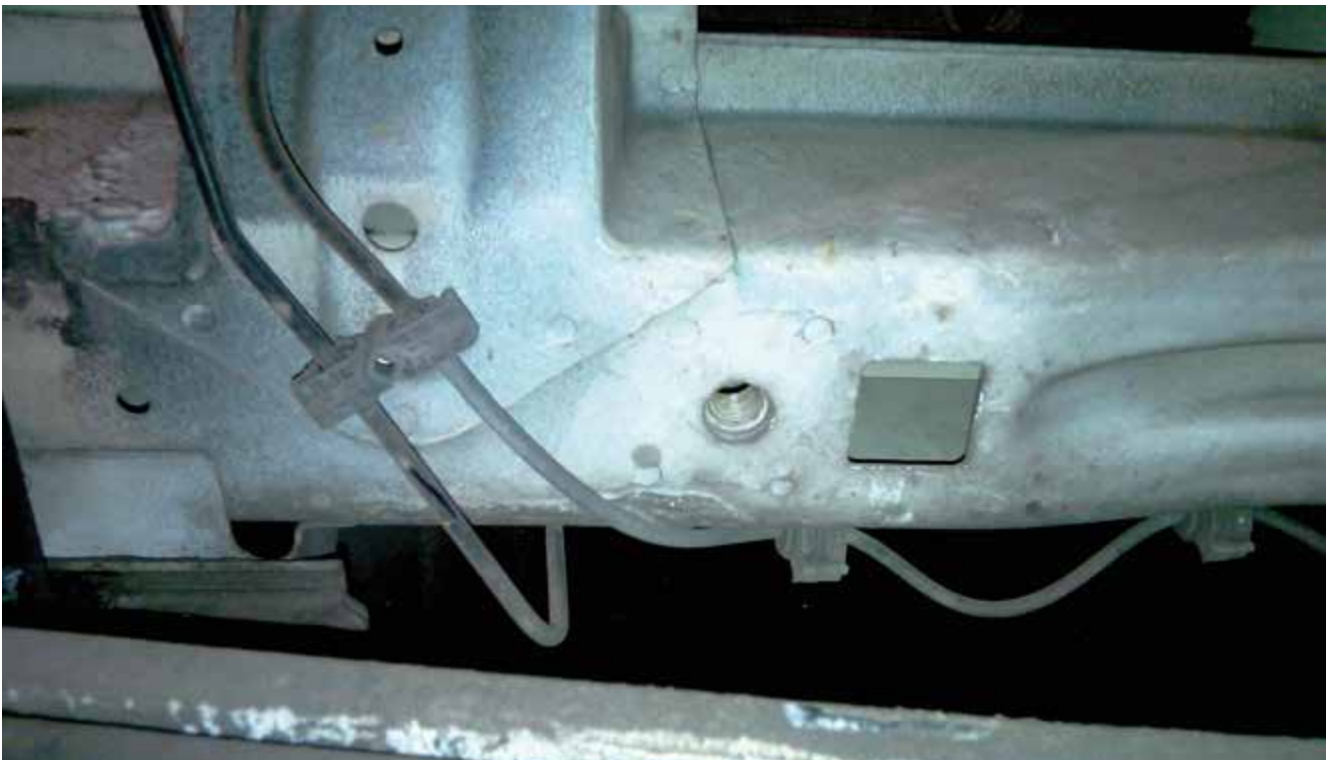

## TAKASOVITIN DUCATO X250 (TAKA-AKSELIN EDESSÄ)

### VAIHE 2:



Aseta tiivistyslevy paikalleen ja aseta se paikalleen (levy, jossa on yksi reikä) ja kiinnitä se sitten pulteilla (10 mm x 70 mm ja 14 mm x 70 mm)

Huomio! Molemmat takatunkit moottorin kanssa kohti ajoneuvon keskiosaa, kierto kohti etuosaa.

## TAKASOVITIN DUCATO X250 (TAKA-AKSELIN TAKANA) VAIHE 1:





(siirrä sähköjohdot, aseta sovitin sen yläpuolelle)



**VAIHE 2:**

Kiinnitä sovitin pulteilla (4 kpl - 10 mm x 70 mm), kiinnitä sitten tunkit.



Varo: Molemmat takatunkit on sijoitettava siten, että moottori on ajoneuvon keskiosaa kohti, ja niitä on voitava kääntää eteen tai taakse.



# Autolift System

---

**ADAPTER FOR DUCATO X250/290**  
**Art.465102**

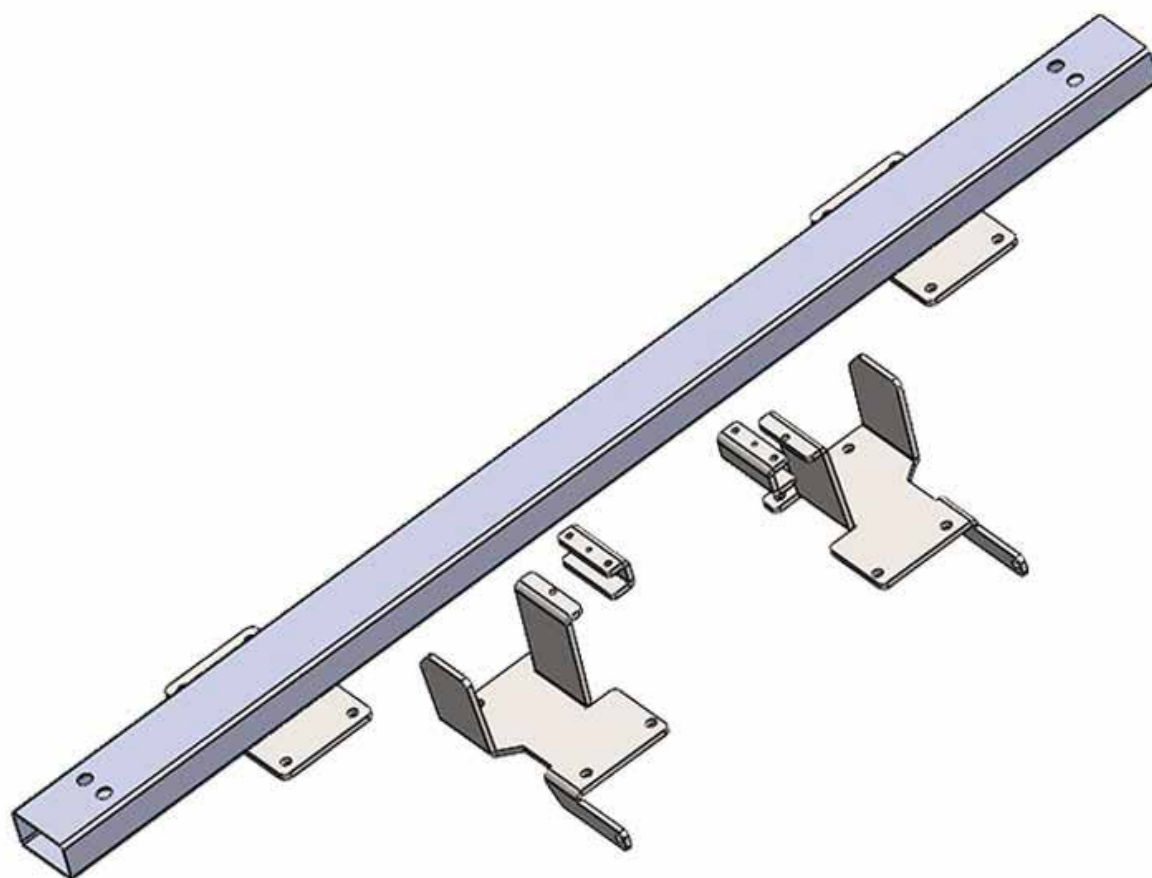

## ADAPTER FORAN HØJRE DUCATO X250/290

### TRIN 1:



Sæt adapteren så langt tilbage som muligt. Fjern om nødvendigt tætningsmateriale for at opnå bedre fastholdelse. Brug en flaskevogn til at fastgøre beslaget i den korrekte position og lav et 8 mm sidehul, og fastgør det derefter med en bolt.

### TRIN 2:



Påsat klemmen

Vær opmærksom: Motorvognen placeres med front mod køretøjets yderside, rotation mod fronten

## ADAPTER FORAN VENSTRE DUCATO X250/290

### TRIN 1

Brug samme procedure som for den højre adapter

### TRIN 2



Placer klemmen mellem tanken og chassiset, vær opmærksom på rørene. I nogle tilfælde kan det være nødvendigt at løsne skruerne, der fastgør tanken, lidt for at flytte den 1-2 cm væk fra chassiset.

### TRIN 3:



I sjældne tilfælde kan det være nødvendigt at slibe for at opnå den korrekte rotation af donkraften  
Opmærksomhed: Motorvognen anbringes med front mod køretøjets yderside, rotation mod fronten.

(BEMÆRK) DET ER MULIGT AT FASTGØRE DEN BAGESTE ADAPTER FORAN ELLER BAG BAG BAGAKSLEN

### BAGADAPTER DUCATO X250 (FORAN BAGAKSLEN)

#### TRIN 1:

Bagadapteren skal placeres bag bag bagakslen, som vist på billedet:

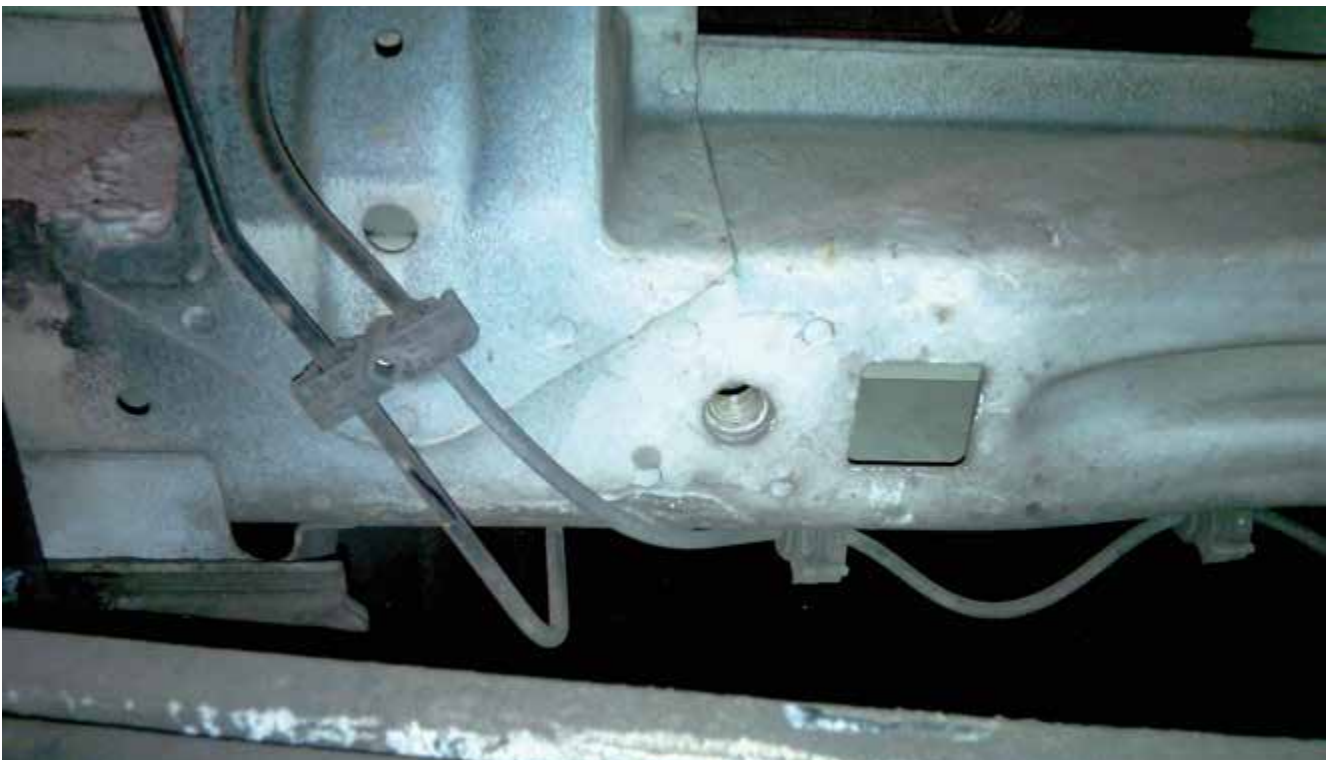

BAGADAPTER DUCATO X250 (FORAN BAGAKSLEN), SOM VIST PÅ BILLEDET: BAGADAPTER DUCATO X250 (FORAN BAGAKSLEN)

TRIN 2:



Placér og indsæt tætningspladen (plade med et hul), og fastgør den med boltene (10 mm x 70 mm og 14 mm x 70 mm)

Opmærksomhed: Begge bageste donkrafte med motoren mod midten af køretøjet, rotation mod fronten.

## BAGADAPTER DUCATO X250 (BAG BAG BAGAKSLEN)

TRIN 1:





(flyt de elektriske ledninger, indsæt adapteren over den)



**TRIN 2:**

Fastgør adapteren ved hjælp af boltene (4 stk. - 10 mm x 70 mm), og fastgør derefter donkrafterne.



Pas på: Begge bageste donkrafte skal placeres med motoren mod midten af køretøjet, så de kan drejes mod for eller bag.



# Autolift System

---

**ADAPTER FÖR DUCATO X250/290**  
**Art.465102**

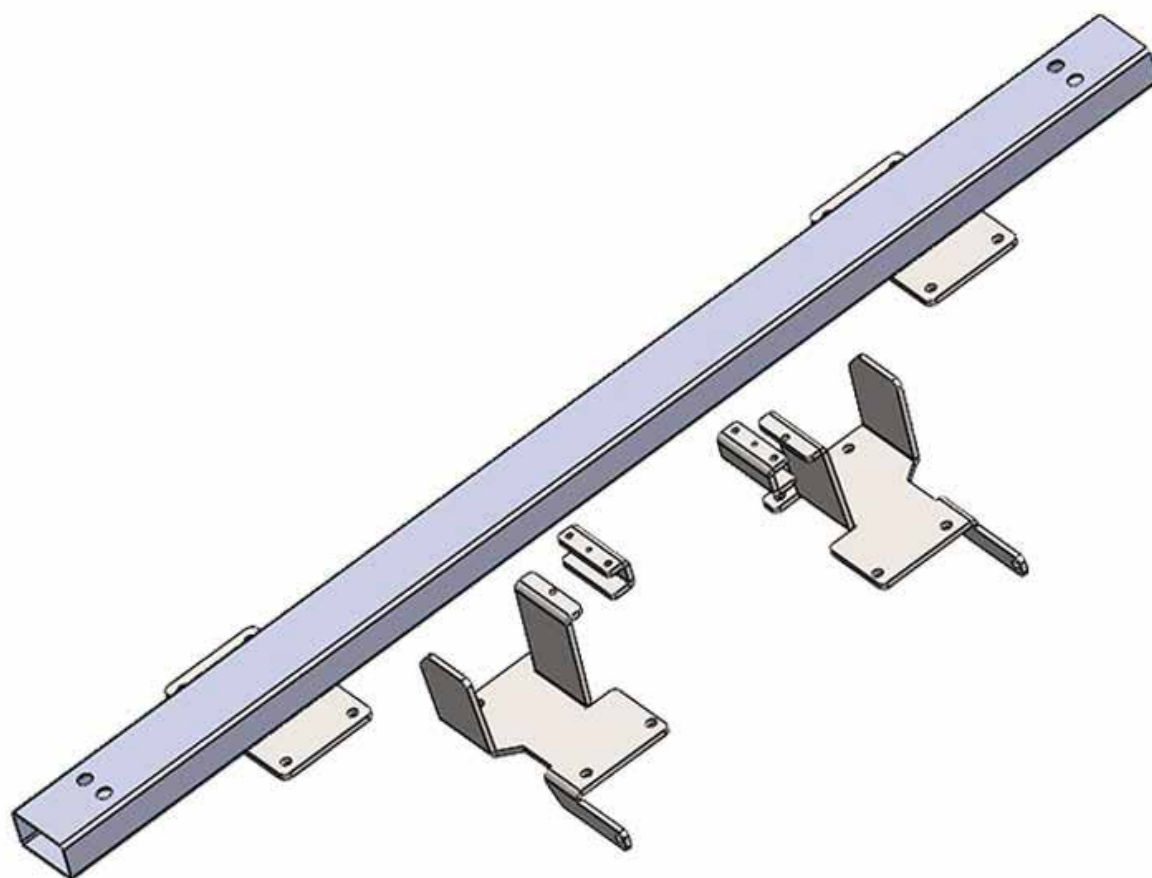

## ADAPTER FRAM HÖGER DUCATO X250/290

### STEG 1:



Placera adaptorn så långt bak som möjligt. Ta vid behov bort eventuellt tätningsmaterial för att få en bättre vidhäftning. Använd en flaskstuds för att fixera fästet i rätt läge och gör ett 8 mm sidohål, fäst det sedan med en bult.

### STEG 2:



Applicera klämman

Uppmärksamhet: Motorjack placeras med ansiktet vänd mot fordonets utsida, rotation mot framsidan

## FRAMSIDA VÄNSTER ADAPTER DUCATO X250/290

### STEG 1

Använd samma förfarande som för den högra adaptorn

### STEG 2



Placera klämman mellan tanken och chassit, var uppmärksam på rören. I vissa fall kan det vara nödvändigt att lossa skruvarna som fäster tanken något för att flytta den 1-2 cm från chassit.

### STEG 3:



I sällsynta fall kan det vara nödvändigt att slipa, i strävan efter korrekt rotation av domkraften  
Uppmärksamhet: Motordrivna domkraften placeras med ansiktet vänd mot fordonets utsida, rotationen mot framsidan.

(OBS!) DET ÄR MÖJLIGT ATT FÄSTA DEN BAKRE ADAPTERN FRAMFÖR ELLER BAKOM BAKAXELN

### BAKRE ADAPTER DUCATO X250 (FRAMFÖR BAKAXELN)

#### STEG 1:

Den bakre adaptern måste placeras bakom bakaxeln, enligt bilden:

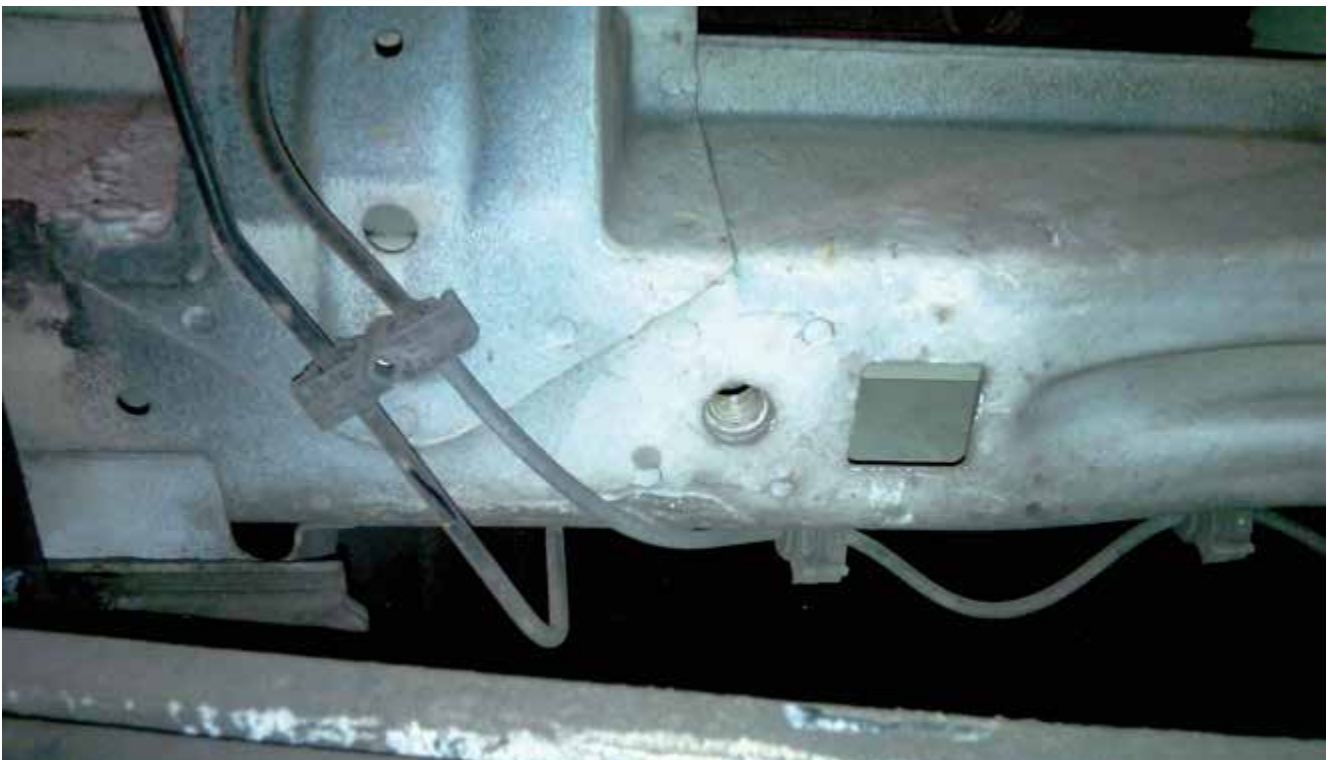

**BAKRE ADAPTER DUCATO X250 (FRAMFÖR BAKAXELN)****STEG 2:**

Placera och sätt in tätningsplattan (platta med ett hål) och fäst den sedan med skruvarna (10 mm x 70 mm och 14 mm x 70 mm)

Uppmärksamhet: Båda bakre domkrafterna med motorn mot fordonets mitt, rotation mot framsidan.

## BAKRE ADAPTER DUCATO X250 (BAKOM BAKAXELN) STEG 1:





(flytta den elektriska ledningen, sätt in adaptern ovanför den)



**STEG 2:**

Fäst adaptern med hjälp av bultarna (4 stycken - 10 mm x 70 mm) och fäst sedan domkrafterna.



Akta dig: Båda de bakre domkrafterna ska placeras med motorn mot mitten av fordonet, så att den kan rotera framåt eller bakåt.







REIMO REISEMOBIL-CENTER GMBH  
63329 EGELSBACH · BOSCHRING 10 · GERMANY · [WWW.REIMO.COM](http://WWW.REIMO.COM)  
MADE IN ITALY · © REIMO 04/2022